

Lineup

AC-1- α For press machine 15 ~ 35t

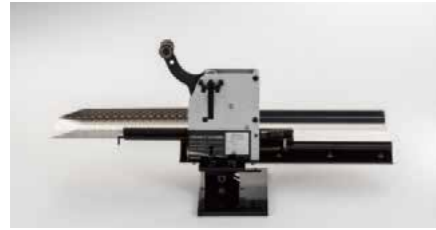

AC-2- α For press machine 45 ~ 80t

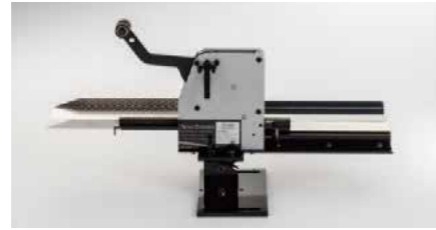

AC-3- α For press machine 100 ~ 200t

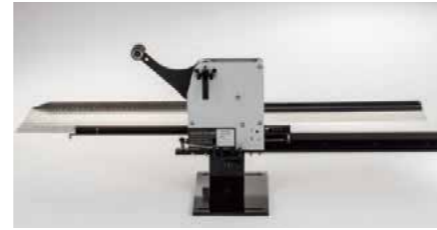

Specification

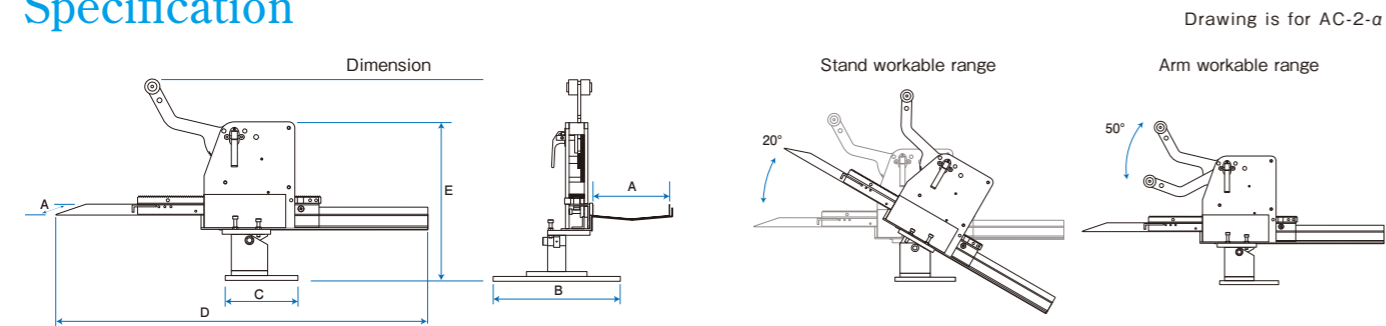

Drawing is for AC-2- α

Model	A	B	C	D (Min.~ Max.)	E (at horizon)	Tray movable width	Net weight
AC-1- α	130 mm	210 mm	120 mm	440~600 mm	215 mm	Max. 180 mm	Approx. 6kgs
AC-2- α	130 mm	210 mm	120 mm	440~620 mm	250 mm	Max. 200 mm	Approx. 7kgs
AC-2- α (280 type)	130 mm	210 mm	120 mm	540~820 mm	250 mm	Max. 280 mm	Approx. 8kgs
AC-3- α	200 mm	260 mm	170 mm	650~1000 mm	315 mm	Max. 370 mm	Approx. 18kgs
AC-3- α (450type)	200 mm	260 mm	170 mm	720~1170 mm	315 mm	Max. 450 mm	Approx. 19kgs

※Arm's shape for AC-2- α (280 type) and AC-3- α (450 type) is shorter than the standard type. The details shall be referred to Option Catalogue.

Criteria of operation environment

Model	Permissible range of press machine	Tray Max. movement [necessary die height]	Thickness range of work	Max. size of work	Allowed range of work weight
AC-1- α	15~35 t	180 mm [100 mm or more]	t 0.5~1.6 mm	50×50 mm	10~40 g
AC-2- α	45~80 t	200 mm [110 mm or more]	t 0.5~1.6 mm	80×80 mm	30~100 g
AC-2- α (280 type)	45~80 t	280 mm [120 mm or more]	t 0.5~1.6 mm	80×80 mm	30~100 g
AC-3- α	100~250 t	370 mm [120 mm or more]	t 0.5~3.2 mm	150×150 mm	150~500 g
AC-3- α (450type)	100~250 t	450 mm [140 mm or more]	t 0.5~3.2 mm	150×150 mm	150~500 g

※Arm shape for AC-2- α (280type) and AC-3- α (450type) is shorter than standard type. The details shall be referred to Option Catalogue.

※In case that Tray Max. movement is not available because of short die height, you are requested to use "short arm" (customize).

The details shall be referred to Option catalogue.

YouTube

<http://www.auto-catcher.biz>



S.A.R.L TSF

19 rue Jean Bourgey 69100 VILLEURBANNE France
TEL(FAX):+33(0)4 37 57 02 77 E-MAIL:tsf.sarl@orange.fr

mikumo
production power

AUTO CATCHER

version. α

New type catcher to put making production efficient and improvement of safety of compound press work into practice.

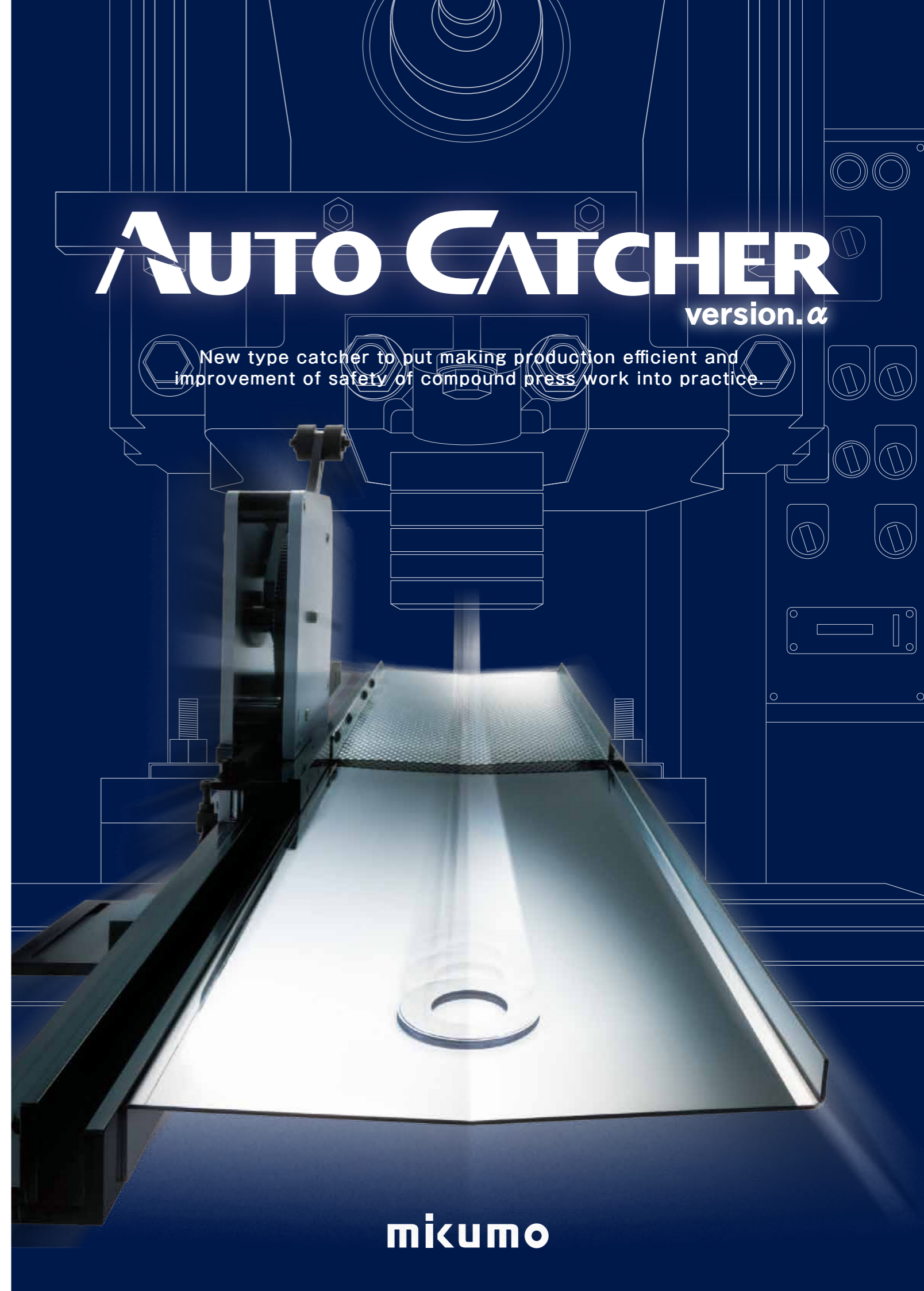

mikumo

Production Revolution

This is an unloading equipment(Auto Catcher) of pressed parts of the new way of thinking which we perform so smoothly that we are surprised in unloading the manufactured goods which is also a subject of compound blanking work(Compound forming with knockout bar).

It answers various needs, such as liking to improve a productivity and liking to work safely.

And, by making a material feed into coil material, it can realize automation.

It means that it should be an attachment which contributes to a production greatly.

We propose new solution to manufacturers keeping challenge from us being familiar with press work.



Patent No.4086884

Action 1 Catch without mistake 2 Slide smoothly 3 Shoot without mistake

[Top Dead Center]

Parts fall by knockout.

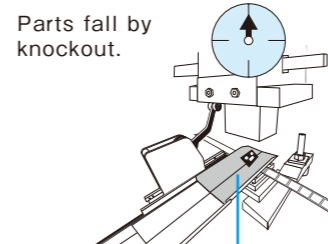

Press machine ▶

[Middle Point]

Tray works and parts slide.

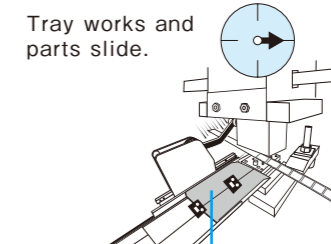

Auto Catcher ▶

[Bottom Dead Center]

Press machine produces again.

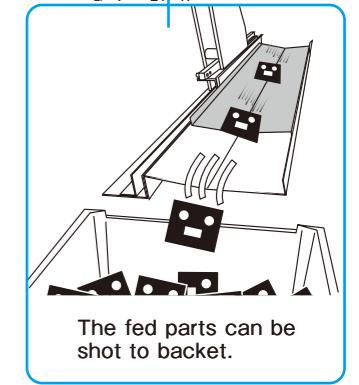
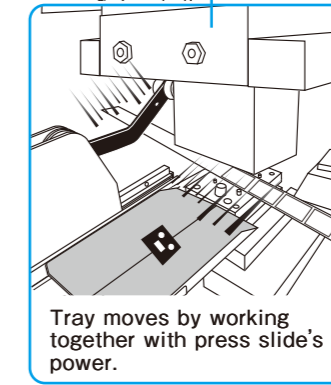
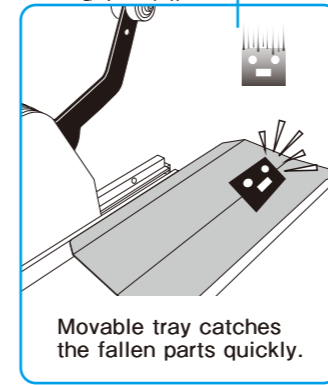
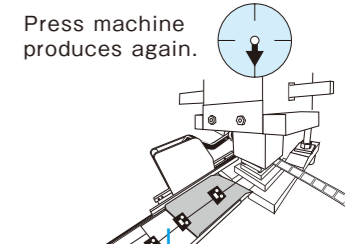

Before / After

《Problems of conventional method》

- Blow off by air that causes quality defect and risk of Dies-Broken.
- Limit of production efficiency by only worker.
- Risk of accident being caught (jamming). etc.

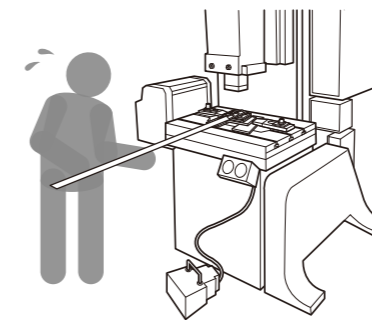

《Using Auto Catcher》

- **Reduction of rejected parts and no risk of Dies-Broken.**
- **Increase of production efficiency to a big extent.**
- **Avoid risk of accident being caught (jamming). etc.**

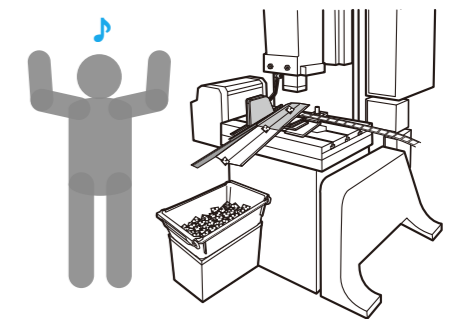

Advantage



High productivity

Production efficiency can be increased rapidly, compared with only process of operator. It contributes to a big extent to the solution of small lot, multi kinds of parts and short delivery and to the cost reduction.



Realization of labor saving and manpower saving

Auto catcher assists a worker and contributes to labor saving and manpower saving regarding not only safety but also improvement of workability and reduction of processing time.



Improvement of safety

Most accident in press work is "Accident being caught(Jamming)". Such dangerous work can be solved by "Auto Catcher". We avoid working risk and promote safety measure.



Excellent versatility

Different from conventional unloader fixed to press machine, it is easy to remove it from press machine and is potable type. It can be used also to another press machine as per production situation.



Easy installation

Without troublesome arrangement, it is possible to install this equipment in approximate several minutes. And due to simple design, it is very easy to carry it and maintain it.



No need of electric power

This is easy to ecology and economical. Because you don't need electric power etc., as it utilizes kinetic energy of press machine.



Contribution to reduction of noise and electricity charges

It is released from the noise at the time of an air emission, and it offers a comfortable working environment. Furthermore, since a use of a compressor decreases, you can save electric cost.